

The 12 volt Side of Life Part 2.

OK, now that you know all about batteries and charging, lets put some of that stored energy to use. There are a lot of things that you can do to make your RV home more comfortable and energy efficient. There are even a few projects illustrated to spur your creative urges.

- **Inverters**

One of the most useful items that you can add to your RV is an inverter. Inverters make 110 volt AC power from your 12 volt battery system. This will allow you to operate many of your appliances and accessories that require AC power without the noise and cost of operating a generator. Inverters range from simple portable units that plug into your cigarette lighter to larger, hard wired units that are permanently installed. AC wattage ratings are available from 100 watts up to 4000 watts or more. About the only thing that you won't be able to operate with a suitably sized inverter is your air conditioner... the huge size of the battery bank required makes it impractical. Most other appliances are fair game. Picking the right inverter isn't difficult. You need to decide just what it is that you wish to accomplish and how much battery capacity you have available.

Sizing. Let's start by determining what it is that you want to operate. Here's a table listing some of the more common appliances and their wattage requirements.

Appliance	Wattage (approx.)	Appliance	Wattage (approx.)
13" color TV	50	Computer	70
19" color TV	120	Computer monitor	55
Stereo	50	Computer printer	20
VCR	25	Hand mixer	100
Satellite Receiver	20	Blender	350
Heating pad	50	Toaster	1250
Electric blanket	150	Microwave	650-1000
Electric drill	500	Coffee maker	1250 brew, 200 warm

It's obvious that your microwave requires quite a lot of power. Most ovens will draw 650 - 1000 watts. Starting surges can be as high as 1500 watts. If you want to be able to use your microwave with your inverter, your inverter should be capable of producing at least 1000 watts and be rated for a 1500 watt surge. If you want to be able to use resistance heated appliances, like a toaster oven or electric coffee maker, be sure that the inverter you choose has a high enough rating. Most of these appliances will require 1200 to 1500 watts. They don't have a starting surge, like motors or microwaves, but are hungry for watts. When in doubt, consult the owners manual for the appliance or check the ratings plate for wattage requirements.

Now is a good time to discuss just what these wattage numbers really mean in terms of 12 volt battery power. First, we need to do a little math... Hey, wait... come back here! I promise that it will be simple and won't require you to buy a scientific calculator to figure it out! What we need to do first is figure out how many DC amps the inverter will draw when it's making that AC power for your appliances. Put simply, for every 100 watts of AC power that your inverter is producing, it

needs to draw about 10 amps from your 12 volt battery system. For inverters rated at 90% efficiency, the number is closer to 9.25 amps per 100 watts, but for ease of calculation, just assume that 10 amps DC per 100 watts AC... it's easier to figure that way and errs on the side of safety. For those of you who just MUST have the math, here it is: **Watts = Volts x Amps**, so **Amps = Watts / Volts**. For an inverter, operating at 90% efficiency, the conversion can be represented thus: **AC watts / 12 volts X 1.11 = DC amps**

Example... television drawing 100 watts operating on an inverter will draw about 9.25 amps from your batteries..

$$100 / 12 \times 1.11 = 9.25$$

The reason that this is important is that you only have a fixed capacity in amp/hours available from your battery bank. A pair of 6v deep cycle batteries or a pair of group 24 RV batteries will have a capacity of about 200 amp hours. That means that if you run that TV from the previous example for about 20 hours, your batteries will be flat! **9.25A X 20 hours = 185 amp/hours.**

Still with me? Good! Using the chart on wattage requirements and adding our new-found knowledge of amp hours, lets take a shot at how many amp hours of battery bank we need to supply us for a standard days use.

Appliance	Watts	Use Time	Watt Hours	Amp Hours
13" color TV	50	3 hr.	150	15
Satellite Receiver	20	3 hr.	60	6
Computer/monitor	125	2 hr.	250	25
Coffee Maker	1250	20 min	417	41.7
Microwave	1000	15 min.	250	25
		Totals >	1127	112.7

Don't forget that you are also using power from your batteries to run 12 Volt lighting, fans, water pump, etc.

You begin to see that putting in a larger inverter to run bigger loads will require you to have an appropriately sized battery bank and an adequate method for recharging it! You can't hook a 2000 watt inverter to a single battery and cook the Thanksgiving turkey in the microwave! You should get a feel for your intended inverter usage and take into account the size of your battery bank before selecting an inverter. In my personal case, I chose a 750 watt inverter to go with my 2 battery bank. I didn't have room or weight capacity for more batteries, so I went with a smaller inverter. It runs all my electronics, charges power tools, runs kitchen tools, but won't support my microwave or toaster oven. It was a good compromise for my situation. It was also a lot cheaper, as my inverter was about \$500, compared to the \$900+ that I would have paid out for a 1500 watt unit. And that brings us to the next topic:

Hybrid Systems. Often, it is more cost effective to purchase a smaller inverter to run the small appliances that you have and use a generator to power the more watt-hungry larger appliances, like the microwave and coffee maker. This will give you quiet power for most uses and minimize the wear and tear on your generator. If you can't manage a full sized battery bank and large inverter, this hybrid approach may work better for you. It is the approach that I chose to use, and it works well for me.

Inverter types There are 3 main types of inverters. Square Wave, Modified Sine Wave and True

Sine Wave. Let's look at the differences:

Square Wave inverters are the cheapest. They also are usually the least efficient and will not run any of your electronic equipment. The reason for this is that the AC waveform they produce is very different from what you get at a standard wall outlet. Instead of being a sine wave it is a square wave. These inverters are usually functional for power tools and motors, but will not work with your TV or stereo. Definitely not recommended!

Modified Sine Wave inverters are the middle of the road. They produce an output wave form that is close to a true sine wave and will work adequately with most devices, including TVs and computers. You may be able to see some slight distortion lines on the TV or hear a slight buzz on the stereo, but for the most part, these inverters provide quite acceptable performance. One noted exception is that most laser printers won't work properly with a Modified Sine Wave inverter. They are also middle-of-the-road as far as cost goes.

True Sine Wave inverters are exactly that. They produce a practically perfect sine wave output. These units will operate even the fussiest electronic device, but they are much more expensive than their cousins, the Modified Sine Wave inverters. Do you need one? Probably not, unless you simply **MUST** have the best, or are trying to get a highly sensitive piece of equipment to work in your RV.

Battery Charging. Many of the better inverters designed for RV use are also high quality battery chargers. This is an excellent option, as it allows you to get rid of that old, inefficient converter and enjoy faster, safer 3 stage charging. Most of the major inverter manufacturers offer this either as standard equipment or as an add-on accessory on their inverters. These chargers typically can deliver from 25 to 150 amps of charge current and run very well with generator power, allowing you to quickly recharge your batteries while out in the boonies. These 3 stage chargers will also not boil the water out of your batteries. Instead, they will bring them to full charge and then taper back to a true float charge... these units can safely be left plugged in continuously, unlike the standard converter found in most RVs.

Costs. You can expect to pay about \$50 to \$100 for a small portable MSW unit. RV designed units start at about \$500 for a 750 watt w/charger and go all the way up to units rated at more than 3000 watts and costing several thousand dollars. Price increases with wattage ratings and capabilities. The best thing I can suggest is to do some research. Check the links listed below for inverter manufacturers and remember to size the inverter based on your real needs.

Project: Installing an inverter. I'm going to take you through the inverter installation that I did for my RV. Your needs and situation will be different, but this should give you some ideas. **A word of Caution:** Always follow the inverter manufacturer's installation guidelines, paying close attention to proper wire sizing. Installing an inverter requires understanding of safe electrical practices and electrical safety code. If you don't have the necessary skills, get a **qualified** electrician to do the wiring. Don't take chances with safety!

Mount the inverter in a compartment where it will be accessible and safe from moisture and flammable items or gases. Inverters utilize some components that can create a spark, so **never** install an inverter in the same compartment as the batteries! I installed mine in the forward compartment underneath the 5th wheel overhang.



The next step was to wire the AC side of the inverter to the rigs electrical system. One of the advantages of an installed inverter is the availability of AC power at the same outlets that you're used to using when plugged into shore power. I simply chose the wall outlet circuits that I wanted the inverter to power and modified the rigs breaker panel to accommodate my choices. The Heart Interface inverter that I chose has a built in transfer switch on the AC side. The transfer switch supplies AC line power to the inverter's AC output when plugged into shore power and then switches to the inverter when shore power goes away. It's all completely automatic. I used standard 12-2 w/gnd Romex and fittings to wire up the AC side of my inverter... you will need to supply AC power to the inverter and connect the inverter's AC output to the circuits that you want to function when shore power goes away. This is really simpler than it sounds, so don't worry. Your inverter installation manual will give you some basic examples of installation wiring. Here's a wiring diagram of my installation which is taken right out of the Heart Interface manual:

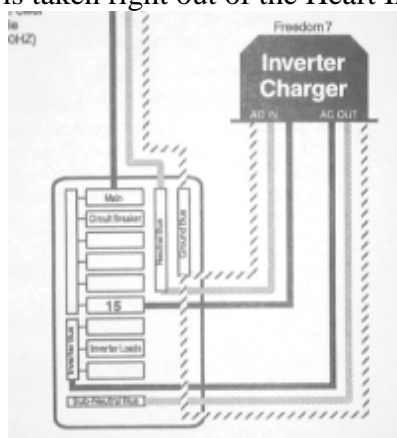

Click [Here](#) for a bigger picture.

The wiring to the battery is done next. After removing the original converter and it's wiring, I installed heavy duty battery cable to connect the inverter directly to the batteries. It's important to use heavy enough wire here, as some larger inverters can draw several hundred amps when under full load! My inverter required 6 ga. wire. I also twisted the heavy wire to help eliminate any electrical interference when operating the unit in charge mode. A fuse was used to protect the system from meltdown. I used a 100A fuse connected directly to the positive terminal of the battery as shown below:



Once all that was done, I ran some wiring for the remote on/off switch for the inverter function. This lets you disable the inverter when it's not needed. You could really leave it on all the time, but the inverter does draw about 1/2 amp in standby (when there is no load on the AC outputs) so I would rather turn it off when not in use to save power. I mounted the switch next to my monitor panel (more on the monitor panel later...) as seen here.



Some of the larger and more expensive inverters offer very sophisticated control panels that will tell you battery voltage, charge/discharge rate, amp hours used, you name it. Very handy, but somewhat expensive. A little further on I will share some tips about constructing your own monitor panel, like I did. In use, the inverter is almost like being plugged in! I can charge my laptop batteries, watch TV or a movie on the VCR, run my kitchen appliances, and all without the noise of a generator. Truly a great addition to your RV if you ever park far from the nearest AC outlet!

Sources. Here are some links to Inverter manufacturers and retailers. In particular, RV Solar Electric's website is well worth a look. They are a very knowledgeable company and have been doing RV systems like these for years. Their prices are very competitive as well. I bought my inverter there and they were very prompt and helpful... give them a look!

Trace Engineering. (360) 435-8826. <http://www.traceengineering.com/>

Heart Interface. (800) 446-6180. In WA (206) 872-7225. <http://www.heartinterface.com/>

EXELTECH. (800) 886-4683. <http://www.exeltech.com/>

STATPOWER. (800) 670-0707. <http://www.statpower.com/>

RV Solar Electric. 14415 No. 73d St., Scottsdale, AZ 85260. (800) 999-8520.

<http://www.rvsolarelectric.com/>

West Marine. Box 50050, Watsonville, CA 95077. (800) 538-0775.

<http://www.westmarine.com/>

Wrangler Power Products. These folks don't sell inverters, but carry a huge selection of the wiring products you'll need to install one... 4444 S.E. 27th Ave., Portland, OR 97202. (800)962-2616. <http://www.wranglernw.com/>

For even more detailed information on inverters, go see [Phred Tinseth's Inverter Poop Sheet](#) on the subject. Phred will give you a lot of great (somewhat opinionated) information on the whole process of choosing an inverter. Well worth your time if you're thinking of installing one! Also, stop by and read some of his other [Poop Sheets](#)... Phred is a fine source of information and he has many articles on a variety of RV related topics. A very useful resource for all you Rvers out there!

• Solar

A big advantage for those of us who spend some time away from hookups is the addition of one or more solar panels to the roofs of our rigs. Solar panels will provide power to charge your batteries whenever you have sunlight. This can extend a dry camping period almost indefinitely and solar is quiet and non-polluting. Even a single panel will help a lot. I have a single 55 watt panel, and it provides almost 6 amps of charge current when in direct sunlight. That doesn't sound like much, but multiply that 6 amps by 10 hours and you're doing some serious battery charging! Several solar panels, a good sized battery bank and an inverter will provide you with many of the luxuries of hookups and will be silent and reliable. The only drawback to solar is it's cost. A single 50 or 60 watt panel can cost you as much as \$400 and larger panels are really pricey... still, it's an attractive option for those who like to spend a lot of time drycamping. A solar system consists of one or more solar panels connected through a charge controller to your RV 12 volt system. Sunlight striking the panels generates power and the charge controller monitors the battery voltage to prevent overcharging. These systems are extremely reliable and maintenance free.

Sizing. The number and size of solar panels may be determined more by your pocket book than any other factor. For all it's advantages, solar remains very expensive. It is definitely worthwhile to have at least a single panel, at least 30 or 40 watts, just to keep your batteries up in storage. A single 50 or 60 watt panel will, in the summer, provide you with as much as 60 or 70 amp hours of charge per day. For those who want to be truly hookup independent, a number of larger panels coupled to a larger battery bank will provide you with plenty of power, even when you have an occasional cloudy day. Cloudy days are the bane of solar charging! Even a high thin cloud layer will cut your charge current by 50% or more, and you'll only get 10-20% of rated power on an overcast day. This is when more panels will help. Most authorities agree that if you calculate your daily average energy usage and then provide enough solar capacity to exceed your daily use by 25%, you'll be all set. Let's think about that a little... If you take that daily usage table that I did for the inverter section and add the calculated additional 12 volt appliance and lighting use, we can come up with a figure to work with... see below

Appliance	Watts	Use Time	Watt Hours	Amp Hours
13" color TV	50	3 hr.	150	15
Satellite Receiver	20	3 hr.	60	6
Computer/monitor	125	2 hr.	250	25
Coffee Maker	1250	20 min	417	41.7
Microwave	1000	15 min.	250	25
			Total >	112.7
Appliance	Amperage	Use Time	Amp Hours	
12 Volt lighting	6A (4 ea. 1.5A bulbs)	3 hr.	18	
12 Volt pump	6A	30 min.	3	
12 Volt fans	3A	2 hr..	6	
		Total >	27	

Grand Total AH >

139.7

Looks like we'll need to replace about 140 amp hours (AH) of usage every day. If we figure that a 60-75 watt panel can produce 60 to 70 AH per day under perfect conditions, then it's reasonable to assume that the same panel will produce an average of about 35 AH per day, due to adverse weather conditions, time of year and other factors. Some days are sunny, some are cloudy..... For planning purposes, we can figure on that **average** output, per panel, of about 35 AH a day. Looks like we'll need at least 4 panels up there, and probably would be better off with five panels. There is always some loss of efficiency when recharging a lead acid battery and a couple of cloudy days will really hurt your overall charge capability! Looks like we will either have to conserve power a bit better, or do some serious investing in solar panels. The truth is, the above example is a bit on the energy extravagant side, but illustrates that it's easier to use power than it is to replace it! My own small system, consisting of a single 55 watt panel, provides adequate power to keep me in business for a week, provided that I am conservative and don't have cloudy weather. If it's cloudy, or I have poor exposure to the sun, I have to run the generator for a couple of hours every few days to charge the batteries.

There are a number of very good sizing guides available on the web... [RV Solar Electric](#) has one you should look at... [click here](#) to check it out... Or consider their Rule of Thumb: "The average RVer, one without unusual needs, generally finds that one 4 amp panel and one 105AH battery (or equivalent) per person provides an adequate system for long term outings. An extra panel and battery provides insurance during bad weather and enough power to handle the unexpected."

Hybrid Systems. Again, sometimes the best answer is a compromise... a small solar system to save \$\$ on panels and a small generator to take up the slack when needed can be the most cost effective way to go. I have an Onan Microlite 2800 Watt genset... it'll just barely run 1 roof A/C unit, or anything else in the rig and uses very little gas. In the summer, with good exposure, I can go a week easily without hookups, using the genset only rarely. It's an approach that you should consider....

Mounting. If you're going to put solar panels on your RV roof, you will be faced with several problems... the mountings must support the panels safely and must hold them on the roof in the face of 70 MPH + winds. It is also preferred that the mounts don't cause your roof to leak! There are several types of panel mounts that have been designed with RV use in mind. Use them! If you do design your own mounts, make sure that they are capable of keeping your panels attached securely to your RV. Some of the available mounting systems provide for tilting the panels in one direction to allow you to maximize output by facing them directly at the sun. Since they only tilt on one axis, you will have to orient your rig to take advantage of this... not always possible. One school of thought is to mount the panels flat on the roof and simply use more panels to make up for the lack of efficiency. I chose to design my own mount for my one panel, using a full length hinge along one side of the panel and a standard crank up TV antenna assembly to provide for tilting the panel. I can crank up the panel from inside the rig to the best available angle and lower it flat to the roof for travel. This arrangement has worked well for me, and the panel is still up there after more than 50,000 miles. The panel is mounted to take advantage of the 5ver's roof line and gives me a wide range of tilt angles.

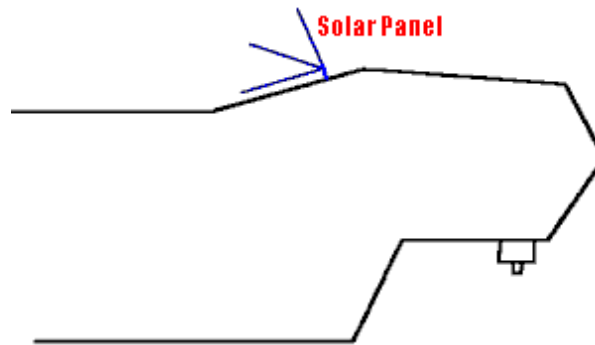

Wiring. Now that your panels are on the roof, it is necessary to get all those electrons from the panel to the battery. Best suggestion is to use as heavy a gauge of wire as possible to reduce losses on the line over distance. Even though my panel maxes out at under 6 amps, I used 10 ga. wire to connect it. Bigger (within reason..) is better! Another problem is how to route the wires into the RV. Drilling holes in the roof is always to be avoided when possible, and it just so happens that most RVs offer some convenient alternatives. If your panels are near the refrigerator roof vent, route the wires down through the roof vent opening and into the interior of the rig. It's also possible to use a plumbing vent. For my installation, I used the black water tank roof vent pipe as a conduit.

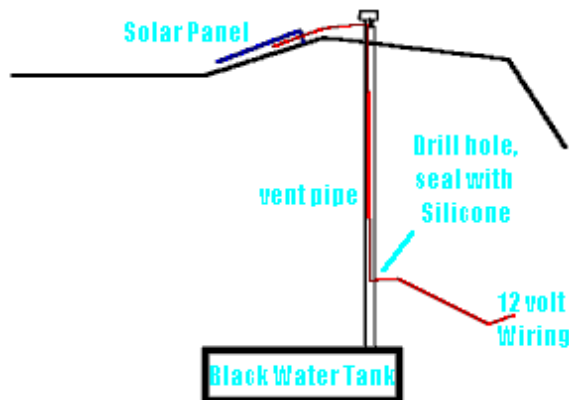

Once inside the RV, the wire can be routed to the location of the battery bank and connected to the charge controller.

Controllers. Although it is possible to directly connect the solar panel(s) to the batteries, it is much better to use a charge controller. This device protects against overcharging of the batteries and also provides a diode to prevent reverse current flow to the panel at night. These controllers can be as fancy as your pocketbook can handle, or very simple. The simple ones will usually cost in the \$50-\$75 range and do the same job as the fancy ones with the meters and computer

monitoring. The controller simply hooks into the charge wiring between the panel and the batteries.

Sources. Here are some links to a number of suppliers of alternative energy systems. Browse some of these sites to get a feel for what's available, costs and applications. Several of these sites have guides to help you design and size your own solar electrical system.

Home Power Magazine: PO Box 520, Ashland, OR 97520. (800) 707-6585.

<http://www.homepower.com/>

RV Solar Electric: 14415 N. 73d St., Scottsdale, AZ 85260 (800) 999-8520.

<http://www.rvsolarelectric.com/>

Real Goods: 555 Leslie St., Ukiah, CA 95482-5507. (800) 762-7325. <http://www.realgoods.com/>

Backwoods Solar Electric Systems: 1395 Rolling Thunder Ridge, Sandpoint, ID 83864 (208) 263-4290. <http://www.backwoodssolar.com/>

Alternative Energy Engineering: Box 339, Redway, CA 95560 (800) 777-6609. <http://www.alt-energy.com/>

Sierra Solar Systems: 109 Argall Way, Nevada City, CA 95959 (800) 517-6527.

<http://www.sierrasolar.com/>

- **Monitoring**

Most RVs come standard with a little analog battery meter or a small LED display. These meters aren't very accurate and aren't much use if you really want to know what's going on in your 12 Volt system. One possibility is to purchase a good quality hand held digital volt meter and use it to monitor the voltage from your batteries. The drawback to this method is that you have to hook it up to your batteries whenever you want to take a reading. A better solution is to install a small digital panel meter and permanently connect it to your batteries. This way, the information is right there at your fingertips. There are a number of these battery monitors available. One place you can look to see some examples of what's available is at the **Backwoods Solar Electric Systems website**. Click [HERE](#) for a look at one of their catalog pages featuring meters. Most of the solar equipment retailers offer a variety of meters to suit your needs, but they can be a little pricey. Still, for an out-of-the-box solution complete with installation instructions, they're hard to beat. You can expect to pay \$40-\$50 for a simple panel voltmeter and as much as several hundred bucks for a really sophisticated system monitor. At the bare minimum, you should have an accurate voltmeter... even better is to have a voltmeter to monitor your battery's state of charge and an ammeter to see what kind of current is going to or from your batteries.

Some of you may be thinking: "Why should I have to pay such close attention to my batteries? Can't I just sort of ignore them and hope for the best?" Well, sure you can! The problem is that when you're dry camping and dependent on your batteries for all of life's little conveniences, it's real easy to use more juice than you put back in... sort of like overdrawing your checking account. The addition of a volt and amp meter will allow you to see how much current you're taking out of the batteries and how much you are putting back in via solar or generator charging. When I installed an ammeter, I was amazed at how much current just a few lights draw, not to mention other 12 Volt items like the furnace and water pump. It's definitely better to know for sure what's going on.

If you plan to install, or have already installed an inverter, you may be able to purchase a very nice monitoring panel as an accessory to your inverter. Most of the major brands designed for RVs have this option available. It can tell you all you need to know and some even have provisions for outside source charge monitoring, from solar panels, for instance. It's worth checking into and will save you having to install your own monitoring system. See the links above in the inverter section and check out some of the manufacturers webpages.

One alternative for you tinkerers out there is to build your own! Simple, battery operated DC

panel meters are available for under \$10 and with a little work, you can have a very nice 12 Volt panel meter for cheap! A little more work and you can cobble up a very functional volt/amp meter. Let's see how:

Project. Build a simple DC Voltmeter for your rig.

This is a simple volt meter that is easy and cheap. The meter runs off a single 9 Volt battery and is very easy to build and install. You can connect it to just about any wiring in the rig that carries unswitched 12 volts and it's small enough to fit just about anywhere. The parts as listed are available from All Electronics Corp. They have a website at <http://www.allelectronics.com/> and you can download their catalog in PDF format and view it.

- o **Parts list**
- o 3 1/2 digit digital voltmeter, panel mount, battery operated, 200mv full scale. Can be purchased for about \$10 from All Electronics Corp. 1-800-825-5432 Part # PM-128
- o Small toggle switch, SPST, pick up anywhere, Radio Shack, your junk drawer, etc. All Electronics Corp. Part # MTS-4 will do just fine.
- o 9 Volt Transistor radio battery.
- o 9 Volt battery connector. All Electronics Corp. Part # BST-8
- o 1 100 Kohm resistor 1/2 watt 0.5%
- o 1 9.99 Mohm resistor 1/2 watt 0.5 %

Follow the directions included with the panel meter. The resistor values listed above are the correct ones for the meter available from All Electronics Corp., but your meter may specify different values to use. The resistors are installed in holes provided on the meter circuit board to form a voltage divider to set the range of the meter to 0-20 Volts. The meter instructions will explain how to do this. Attach the battery connector as specified in the meter instructions. Install the small toggle switch on the battery connector + lead... this is used to turn the meter on and off. You can omit this switch and have the meter on all the time, but it will run down the 9 Volt battery in about 6 months. I chose to use the on/off switch on mine. Mount the meter in your rig in a convenient location, preferably near a 12 volt source. Closer to the battery is better, but not super critical. Connect the meter input leads to the 12 volt source. A fuse would be a good idea if the circuit that you connect the meter to isn't already fused. A 1 amp fuse will be way more than enough, as the meter draws practically no current. See below for a diagram.

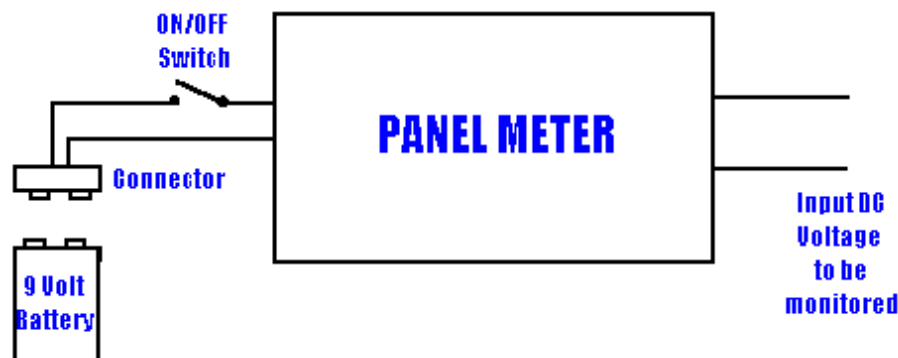

Project. Build a DC Amp meter for your rig.

This is a little more difficult, but worth the effort. The same meter as was used above can also be used to measure DC current if a device called a Shunt is used. Put simply, a shunt is a very accurate, very low Ohm resistor that is placed in the DC positive line directly off the battery. By

measuring the voltage drop across the shunt, we can determine the amperage flowing thru it.

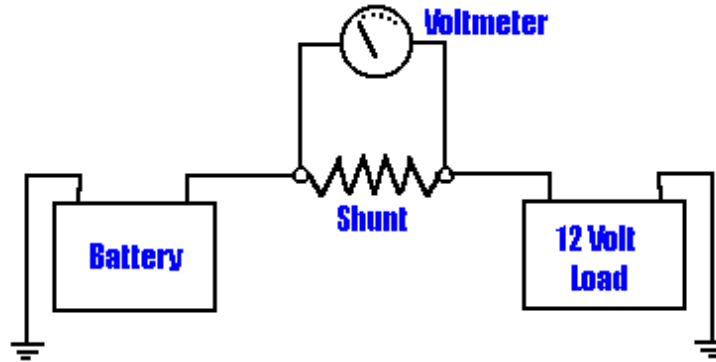

We will be using the same panel voltmeter as above to build our amp meter. Some basic wiring ingenuity and the use of a suitable switch will allow you to use a single panel meter for both functions... more on that later. First, the shunt must be built or purchased. You will need a .01 ohm shunt, one that's rated 10 mvolt / amp. Shunts are available from a variety of sources, but you can also build your own! I constructed mine from a set of 10 .1 ohm 10 watt precision resistors wired in parallel to produce the desired .01 ohm resistance. The resistors are connected by bus bars made of 4 strands of 12 ga. solid copper wire and the whole thing is connected using 8 ga. wire. See the pictures for more info:

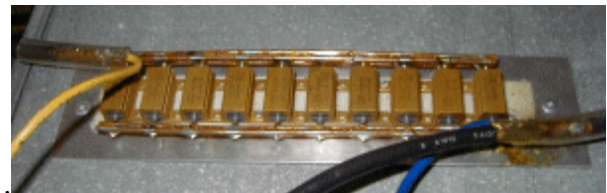
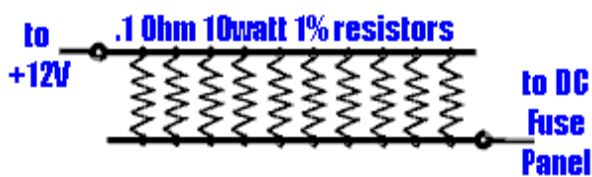

Click [HERE](#) for a bigger picture

The Block diagram for the ammeter looks like this: The meter, set up to it's 200mv full-scale range will measure up to 20 amps using this setup. A change in the meter resistor voltage divider will give you a range to 200 amps, but less resolution. I wouldn't recommend passing 200 amps through this homemade shunt, but it's capable of carrying 50 or 60 amps without frying. The 20 amp scale works well for me, but the one downfall is that this shunt and meter combo isn't large enough to allow the inverter to be hooked up through it. I originally designed this setup long before I had installed the inverter. It's still a very useful setup and may give some of you tinkerers out there some ideas for a design of your own....

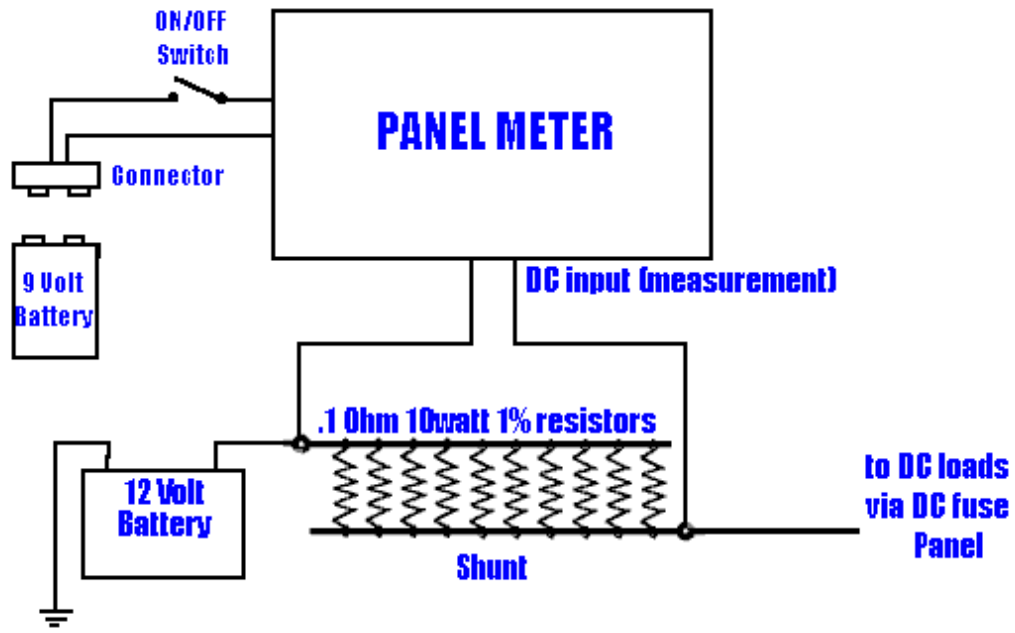

Here's a wiring diagram that I used to build my volt/amp meter for my rig. This allows you to use the one panel meter to monitor both amps and volts.

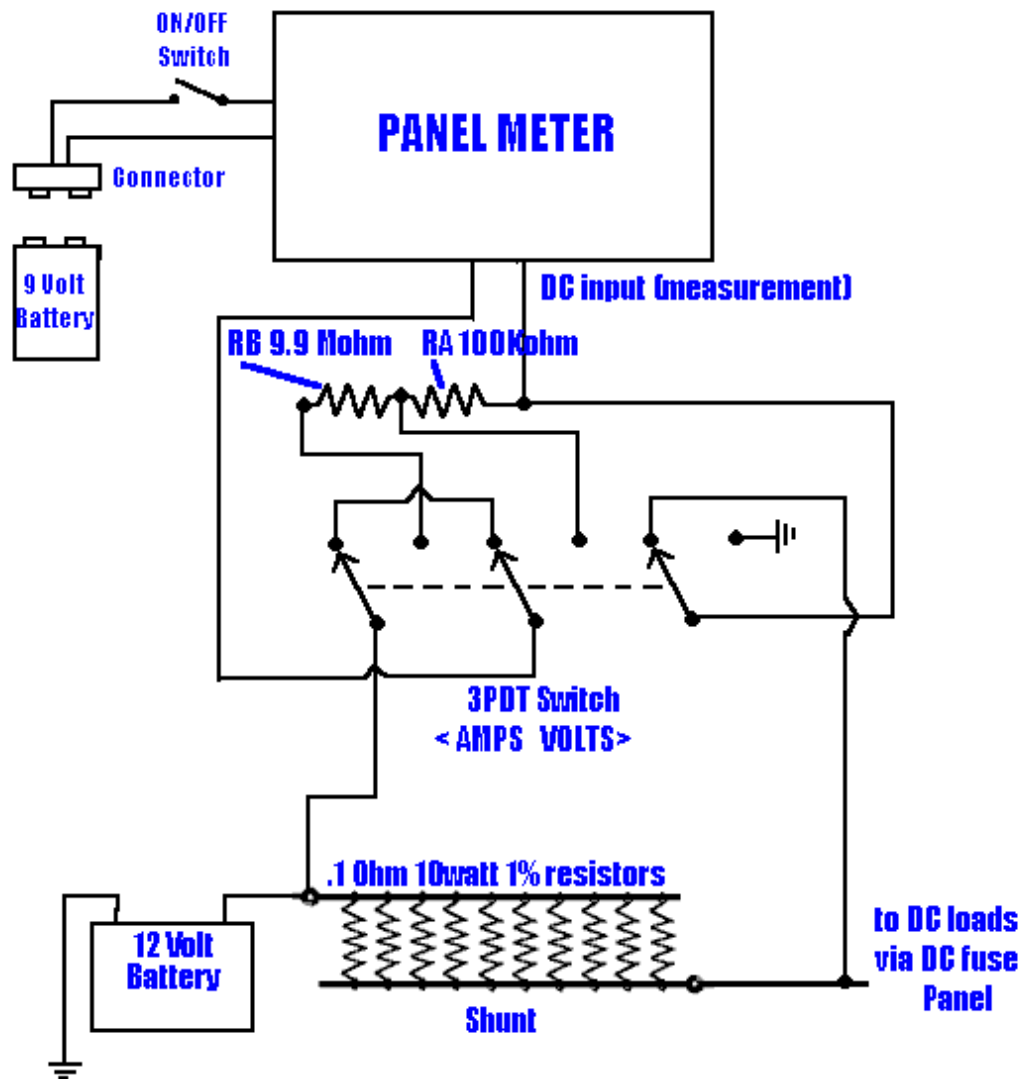

When I designed my monitor panel, I wanted to have everything in one location. The panel has controls for the generator, the volt/amp meter, controls and indicators for the solar panel and a handy 20A cigarette lighter socket with a circuit breaker for heavy duty 12 volt loads. Whether you buy one or build one, it's really worth your while to have at least an accurate voltmeter in your rig to allow you to keep tabs on your battery condition while dry camping. It will extend the life of your batteries by preventing too deep a discharge and will give you the ability to see just how much power you are using and putting back in. Prevent those "bounced" energy checks!! ;-)

- **Wiring**

Most of the 12 Volt wiring in RVs is done using 12 or 14 ga. twinlead. The most common seems to be white with a black trace to denote the positive wire. When in doubt, check with a meter to determine which is positive and which is ground. A lot of RVs also use a crimp style connector to tap into these 12 volt wires to hook up lights and other low current devices. I don't personally care for these crimp connectors as they can fail over time, so any time I make a new connection, I use either wire nuts or solder and heat shrink to make secure connections.

If you intend to install 12 Volt equipment in your RV, it's important to be sure that you use adequately sized wire to meet the amperage requirements of whatever it is that you're installing. Here's a table of wire sizes and amperage ratings that will provide some basic guidelines. This table leans a bit towards heavier wire than is absolutely necessary, but that's actually safer in the long run. Always provide fuse protection of any new wiring that you install. The fuse should be sized so as to protect the wiring from meltdown. Don't put a 20 amp fuse on a circuit wired with 16 ga. wire.

Total Amperage Draw	Up to 4'	4' to 7'	7' to 10'	10' to 13'	13' to 16'	16' to 19'	19' to 22'	22' to 28'
0 - 10	16 Gauge	14 Gauge	14 Gauge	12 Gauge	12 Gauge	12 Gauge	10 Gauge	10 Gauge
10 - 20	14 Gauge	12 Gauge	12 Gauge	10 Gauge	10 Gauge	8 Gauge	8 Gauge	8 Gauge
20 - 35	12 Gauge	10 Gauge	8 Gauge	8 Gauge	6 Gauge	6 Gauge	6 Gauge	4 Gauge
35 - 50	10 Gauge	8 Gauge	8 Gauge	6 Gauge	4 Gauge	4 Gauge	4 Gauge	4 Gauge
50 - 65	8 Gauge	8 Gauge	6 Gauge	4 Gauge	4 Gauge	4 Gauge	4 Gauge	2 Gauge
65 - 85	6 Gauge	6 Gauge	4 Gauge	4 Gauge	2 Gauge	2 Gauge	2 Gauge	0 Gauge
85 - 105	6 Gauge	6 Gauge	4 Gauge	2 Gauge	2 Gauge	2 Gauge	2 Gauge	0 Gauge
105 - 125	4 Gauge	4 Gauge	4 Gauge	2 Gauge	0 Gauge	0 Gauge	0 Gauge	0 Gauge
125 - 150	2 Gauge	2 Gauge	2 Gauge	0 Gauge	0 Gauge	0 Gauge	0 Gauge	00 Gauge

Last but not least, find your RV's 12 Volt Fuse Panel. It could be anywhere. Once you've found it, make a note of the type and sizes of fuses used and go get some spares. Many common fuses found in RVs can be purchased at any automotive parts store. Spares, of the right sizes will come in mighty handy if you should blow a fuse down the road, and having the right size replacement fuse available will hopefully keep you from improvising a temporary replacement (bailing wire) or substituting a larger rated fuse than the one that's blown (very similar to bailing wire!).

• Lighting

Most RVs use simple incandescent light fixtures. These work fairly well, but draw quite a bit of current per bulb. The most common bulbs used are 1073 or 1141 automotive bulbs and they draw about 1.5 amps a piece. Many RVs can benefit from the installation of additional lighting, to help brighten up dark areas or illuminate work areas. In some cases, the existing light fixtures can be moved around or exchanged to provide lighting that better suits your needs. Incandescent fixtures are inexpensive and can be found in any RV supply store or catalog. Although they are inexpensive, when adding new lighting, it is worthwhile to consider alternatives to those standard incandescent fixtures.

Fluorescent lights are excellent for producing large amounts of light for less current. **Sunray** and **Thinlite** both make high quality 12 Volt fluorescent lights in a variety of sizes and configurations. These make great kitchen and workspace lighting. They are a little pricey, at \$30 - \$40 a piece, but work well and last a long time. Avoid those really inexpensive fluorescent fixtures found in some automotive catalogs... they produce rather bluish light and tend to use up tubes at an alarming rate.

For more efficient use of power, consider adding halogen lamps where possible. These fixtures

deliver excellent white light for reading or detail work and use about 1/2 the power of standard incandescent lamps. I'm particularly fond of the lamps that Sunnex offers. I have one near the bed for reading and one by my recliner. Sunnex has a web site and an online catalog Stop by <http://www.sunnexonline.com/shop/20w.htm> for a look. These fixtures are a bit expensive, but well constructed and are flexible to allow them to be adjusted easily for best effect. Click [HERE](#) for a picture of a Sunnex lamp.

• Appliances

There are many 12 Volt appliances and accessories you can buy for your RV. Some work very well and others are basically a waste of time. In my experience, anything that uses resistance heating to accomplish it's goal is a pretty sure bet to be a loser. A good example are the 12 Volt coffee pots you will see advertised in some RV catalogs. Trust me on this one.. they don't work. You will use up lots of battery power for very little result. The main reason is that these items were designed to be used in a vehicle with the motor running, so they are real energy wasters. Ditto on things like 12 volt frying pans and 12 volt toaster ovens. Just don't waste your money. On the other hand, there are a number of 12 Volt devices that will actually improve your quality of life, whether you're plugged into shore power or not. Here are a few of my personal favorites:



Definitely a great addition to any rig... a "Fantastic Fan". This is a high volume 12 Volt fan that replaces one of your existing roof vents. It draws very little current and can really help keep the rig cool without using the A/C. On low, it only draws a couple of amps and on high, it will exchange the air in your rig for cooler outside air in a minute or two. Find them at any camping retailer... Try: <http://www.camperschoice.com/> <http://www.campingworld.com/Adohen Supply Co.>



These are great little fans as well... they run on 12 volts and move a lot of air for only about a 1.5 amp current draw. A couple of these, strategically placed around your rig will keep you a lot cooler! Find them at camping stores or lots of automotive parts stores.



If you have some 12 Volt Cigarette lighter outlets around your rig, one of these small automotive map lights is a handy addition! I use one to light my computer desk and it's great for providing light to type by without a big battery drain. They are also handy to use as night lights and can be removed and stowed when not needed.

• Power saving suggestions for Boondocking.

All right... we've got our battery bank squared away, figured out our charging sources, maybe installed an inverter and are all ready to spend a week out in the wilds, far away from the RV park campers with their convenient hookups. Great! Here are a few tips on how to make life easier for you and your own power company that's contained within your RV. The whole trick to successful

dry camping is conservation. I don't mean huddling around a single flashlight to save battery power... I mean fully utilizing all the functionality of your boondocking home without running out of energy before you're ready to leave. Practice makes perfect, and as you get used to how your system works, you'll feel more confident being electrically independent.

- First off, start out with fully charged batteries.
 - Turn off lights when you don't need them.
 - Turn the radio off when you go outside.
 - Pay attention to those things that draw power and shut them down when you're not actually using them.
 - Watch the battery meter and get a feel for how healthy your batteries are. Refer to the tables from the [12 Volt Side of Life part 1](#). If possible, recharge your batteries before they get down to 50% of capacity, as this will extend their life.
 - If you are using solar panels, pay attention to what's overhead. Park your rig so as to take the best advantage of the sun given where and how your panels are installed. In my case, with my installation, I try to set up so that the rig is headed due south, especially in the winter.... that takes advantage of the angle that my panel can be elevated on.
 - Take advantage of the current that your solar system generates during the day and run high current devices then... charge your laptop batteries with the inverter for later use, take showers and such , etc.
 - When operating on the inverter, beware of phantom loads! Here's a possible scenario: You turn on the inverter to run your computer. That's fine, but if your TV set and satellite receiver are still plugged in from last night, chances are they are still drawing power. This increases the amperage draw of the inverter and can run down your batteries much faster. My Satellite receiver draws exactly the same amount of power whether it's on or "off". My 13" TV draws about 50 watts when it's on and about 12 watts when it's "off". Pretty sneaky, huh? One answer is to put inline switches in the power cords of offending devices. Or, you can simply unplug them.
 - When you run your generator to charge your batteries, why not run an electric heater too, if it's cold or the A/C if it's hot... you're running the genset anyway, right? Or, conversely, if you run your genset for making coffee every morning, your batteries will get a boost of charging right when they need it most... after a long hard night of supplying power for lighting, etc.
 - If you like to dry camp in colder months, you are almost going to HAVE to get a catalytic or radiant propane heater. That forced air furnace that comes standard in most rigs draws 5-7 amps whenever the blower's running. That adds up in a hurry and will leave your batteries severely run down after a couple of cold days. Plus, those furnaces barely approach 60% efficiency, meaning that a lot of your expensive propane is being used to heat the great outdoors, instead of your rig. Check into a catalytic space heater... 95% or better efficiency and no battery drain.
- **The bottom line....**
- Pay attention to your batteries. Maintenance and proper selection pay off in long life.
 - Provide for adequate charging and monitoring. Don't just "plug it in and forget it".
 - Consider an inverter... they add a lot of convenience to your RV, even if you don't dry camp all that much. Make an intelligent choice based on your needs and battery capacity.
 - Consider adding some solar charging capability to your rig. Do your homework and remember: the best thing about solar is that it's modular. Buy some now, expand the system later, you don't have to buy everything all at once.
 - A good monitor panel will make your life away from hookups much easier. Plus, they're fun to play with! Whether you make your own or buy a fancy one, it will give you total control over your own power company.

- If you choose to upgrade your RVs original equipment, or add new accessories, follow good wiring practices. Just because it's only 12 volts doesn't mean that you can do a half-assed job. Use proper wire, of the proper size and fuse new circuits to protect against overloads.
- After all this work, take time enjoy the freedom that electrical independence can bring. Explore some of those more remote spots. Spend some time at Quartzsite or at the rallies and Escapades and never miss that electrical outlet! And most of all, don't ever let that 12 Volt electrical system intimidate you again.... **Knowledge is Power**, and with your **knowledge**, you should have plenty of **power**, no matter where you park!



[Back to previous page](#)



This page last updated on September 10, 2000
© 1999 Mark S. Nemeth